



LCD Display Controller Board Engineer Specification V1.0

Model Name	KEC-MDB03-I
Release Date	2020-04-25
Release Version	V1.0

Prepared by	Checked by	Approved by
Joe Lee	Jason Zeng	Tim Zhang

Shenzhen Ke Chuang Xian Electronic Technology Co., Ltd.

Address: 511, Building B, Zao'an Business Center, No.4003, Shigu Road, Nanshan District, Shenzhen

Tel: +86-13480128872

E-mail: 13480128872@139.com

Copyright ©2018-2020, All Rights Reserved.

Contents

1. Features.....	2
2. Specification.....	4
3. Function Layout.....	5
4. Interface Definition.....	7
5. Mechanical Dimension.....	19
6. Configuration and Precautions.....	20
7. Key Materials List.....	21

Revision History

Revision	Date	Page	Description	Author
1.0	2019.10.24	All	First issued.	Joe Lee

1. Features

- ✚ Resolution up to 4096x2160/60Hz
- ✚ Support 8-bit/10-bit output through either LVDS, V-by-One or eDP
- ✚ Support 8-port LVDS with the speed of each port up to 100MHz
- ✚ Support 8-lane V-by-One
- ✚ Support 8-lane eDP(HBR)
- ✚ Support 4-lane eDP(HBR2)
- ✚ Support DisplayPort 1.2 Multi-Stream Transport(MST) (3 maximal downstream)
- ✚ Support PIP/PBP & 4P
- ✚ Support 3.3V/5V/10V/12V panel voltage(*)
- ✚ 1*Analog RGB input
- ✚ 1*DVI-SL input
- ✚ 1*DVI-DL input
- ✚ 1*HDMI1.4 input
- ✚ 1*HDMI2.0 input
- ✚ 1*DisplayPort1.2 input
- ✚ 2x8W Class-D AMP at 8ohm(option)
- ✚ Line in input & Headphones output(option)
- ✚ Keypad & IR receiver(option)
- ✚ 12V~24V DC power input
- ✚ Standby mode power consumption less than 0.5W
- ✚ Support DDC/CI/2B protocol
- ✚ Support RS-232 protocol

*: Hardware reserved for other panel voltage.

2. Specification

Chipset	Realtek		
Target Market	Medical Display(5MP/6MP/8MP)、Industrial Display		
OSD Language	English、Simplified Chinese		
Panel	Voltage	3.3V/5V/10V/12V/others	
	Interface	8-lane V-by-One 8-lane eDP(HBR) 4-lane eDP(HBR2) 8-port LVDS	
	Resolution	4096x2160/60Hz	
Video Input	Analog RGB	15P D-sub, max. resolution is 1920x1200/60Hz	
	DVI-SL	18+5 DVI-I, max. resolution is 1920x1200/60Hz	
	DVI-DL	24+5 DVI-I, max. resolution is 3840x2160/30Hz	
	HDMI1.4	19P Type-A, max. resolution is 3840x2160/30Hz	
	HDMI 2.0	19P Type-A, Max. resolution is 3840x2160/60Hz	
	DisplayPort 1.2	20P DP, Max. resolution is 3840x2160/60Hz	
Video Output	DisplayPort 1.2 MST	20P DP, Max. resolution is 3840x2160/60Hz	
Power	Power Input	12V~24V DC	
	Normal Consumption	Max. 10W(not include panel consumption)	
	Standby Consumption	< 0.5W	
User Key Function	Power、Menu、Right、Left、Exit		
Special Function	Chip	12-bit video processor	Color processing
		14-bit Gamma	Grayscale processing
		12-bit 3D LUT	Grayscale processing
		FRC+RTC	
		Video Rotate	90/180/270 degree
		Panel Uniformity	Brightness & Color
	Software	Support DICOM	DICOM3.0 Part14(GSDF)
		Support Color Temp. Cal.	Default 2-groups
		Support Gamma Cal.	Default 7-groups

		Support Gamut Cal.	sRGB/Adobe RGB/DCI-P3
		Support BLT function	Option(Need Light Sensor)
		Support Sharkarstain mode	Option
		Support Mono mode	Option

3. Function Layout

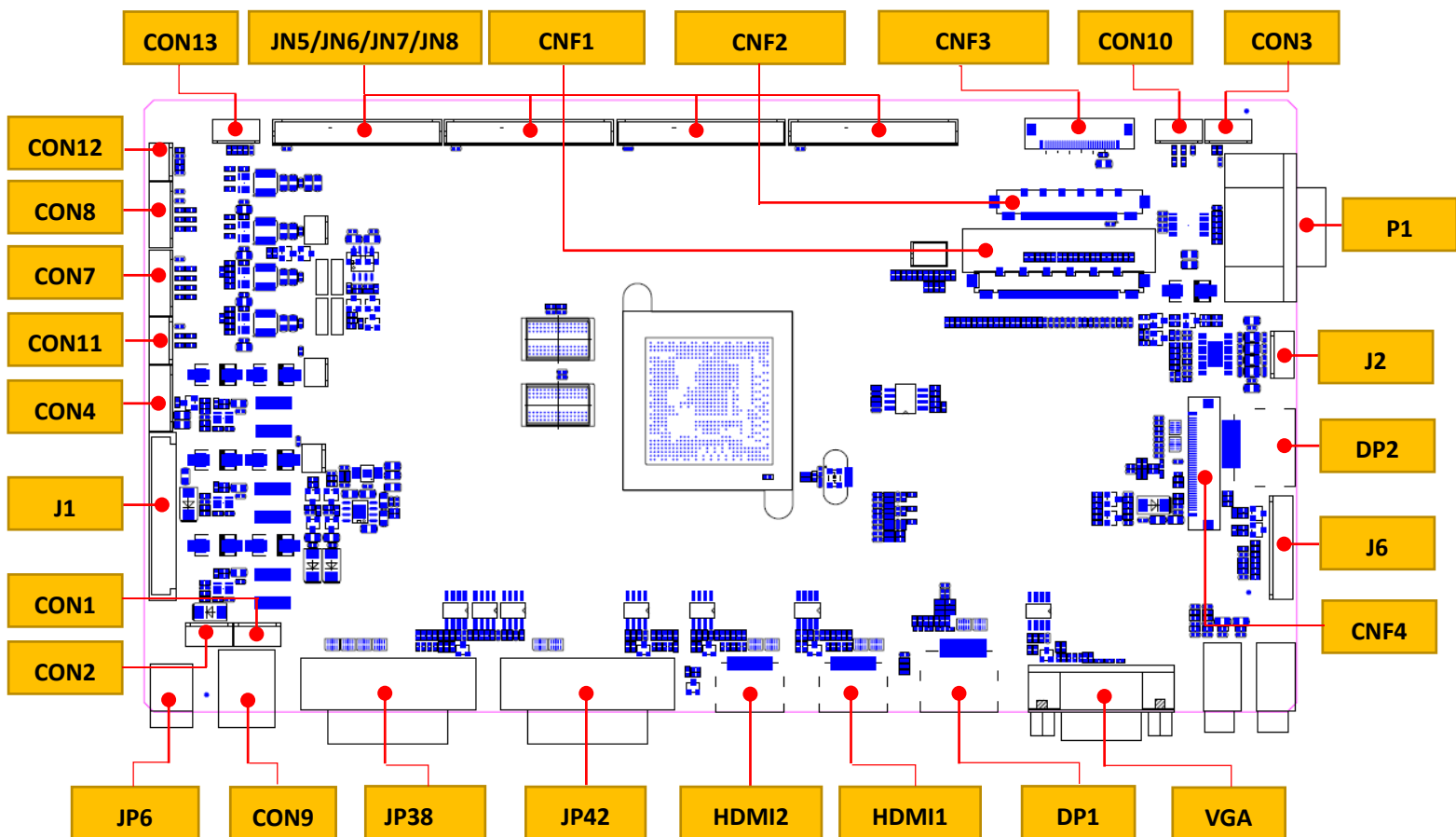

CON1	Touch Interface	PH2.0 4P
CON2	Internal Power Input	PH2.0 4P
CON3	UART Interface	PH2.0 4P
CON4	Backlight Control	PH2.0 6P
CON7	GPIO Output Interface	PH2.0 6P
CON8	PWM Output Interface	PH2.0 6P
CON9	USB Interface	USB2.0 Type-B
CON10	ADC Input Interface	PH2.0 4P
CON11/CON13	IIC Interface	PH2.0 4P
CON12	IR Input Interface	PH2.0 3P
JN5/JN6/JN7/JN8	8-port LVDS Output	PH2.0 2x17P
CNF1	8-lane V-by-One Output	FI-RE51S-HF
CNF2	8-lane eDP(HBR) Output	FI-RE41S-HF
CNF3	4-lane eDP(HBR2) Output	I-PEX 20455-030E-xx

CNF4	4-lane eDP(HBR2) Output	I-PEX 20455-040E-xx
J2	Speaker Output	PH2.0 4P
P1	RS-232 Interface	DB-9 9P
VGA	VGA Signal Input	D-sub 19P
DP1	DP Signal Input	
DP2	DP1.2 MST Output	
HDMI1	HDMI2.0 Signal Input	19P type-A
HDMI2	HDMI1.4 Signal Input	19P type-A
JP42	DVI-SL Signal Input	18+5P DVI-I
JP38	DVI-DL Signal Input	24+5P DVI-I
JP6	12V~24V DC Input	DC2.0 Jack
J1	External Power Module Supply Input	PH2.54 13P
J6	Keypad Interface	PH2.0 10P

4. Interface Definition

4.1 VGA Signal Input

Location - VGA: 15P Female D-Sub

Pin assignment and definition:

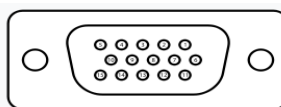

Pin No.	Symbol	Description	Pin No.	Symbol	Description
1	VGA_R+	RED video	9	VGA5V	VGA 5V
2	VGA_G+	GREEN video	10	GND	Ground
3	VGA_B+	BLUE video	11	GND	Ground
4	GND	Ground	12	DDC SDA	IIC serial data
5	GND	Ground	13	HSIN	Horizontal sync
6	VGA_R-	RED return	14	VSIN	Vertical sync
7	VGA_G-	GREEN return	15	DDC SCL	IIC serial clock
8	VGA_B-	BLUE return			

4.2 DisplayPort Signal Input

Location - DP1/DP2: 20P

Pin assignment and definition:

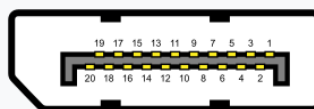

Pin No.	Symbol	Description	Pin No.	Symbol	Description
1	ML_Lane 3 (n)	Lane 3 (negative)	11	GND	Ground
2	GND	Ground	12	ML_Lane 0 (p)	Lane 0 (positive)
3	ML_Lane 3 (p)	Lane 3 (positive)	13	CONFIG1	Connected to ground
4	ML_Lane 2 (n)	Lane 2 (negative)	14	CONFIG2	Connected to ground
5	GND	Ground	15	AUX CH (p)	Auxiliary CH (positive)
6	ML_Lane 2 (p)	Lane 2 (positive)	16	GND	Ground
7	ML_Lane 1 (n)	Lane 1 (negative)	17	AUX CH (n)	Auxiliary CH (negative)
8	GND	Ground	18	Hot Plug	Hot plug detect
9	ML_Lane 1 (p)	Lane 1 (positive)	19	Return	Return for power
10	ML_Lane 0 (n)	Lane 0 (negative)	20	DP_PWR	Power for connector

4.3 HDMI Signal Input

Location - HDMI1/HDMI2: 19P Type-A

Pin assignment and definition:

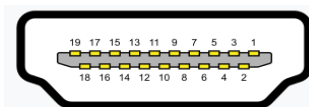

Pin No.	Symbol	Description	Pin No.	Symbol	Description
1	Data2+	TMDS data2+	11	GND	Ground

2	GND	Ground	12	Clock-	TMDS clock-
3	Data2-	TMDS data2-	13	CEC	CEC
4	Data1+	TMDS data1+	14	NC	NC
5	GND	Ground	15	DDC SCL	IIC serial clock
6	Data1-	TMDS data1-	16	DDC SDA	IIC serial data
7	Data0+	TMDS data0+	17	GND	Ground
8	GND	Ground	18	+5V	+5V
9	Data0-	TMDS data0-	19	HPD	Hot plug detect
10	Clock+	TMDS clock+			

4.4 DVI Signal Input

Location - JP42: 18+5P DVI-I Single-Link



Pin assignment and definition:

Pin No.	Symbol	Description	Pin No.	Symbol	Description
1	Data 2-	Digital red- (link 1)	16	HPD	Hot plug detect
2	Data 2+	Digital red+ (link 1)	17	Data 0-	Digital blue- (link 1)
3	GND	Ground	18	Data 0+	Digital blue+ (link 1)
4	NC		19	GND	Ground
5	NC		20	NC	
6	DDC SCL	IIC serial clock	21	NC	
7	DDC SDA	IIC serial data	22	GND	Ground
8	NC		23	Clock+	Digital clock+ (link 1/2)
9	Data 1-	Digital green- (link 1)	24	Clock-	Digital clock- (link 1/2)
10	Data 1+	Digital green+ (link 1)	C1	NC	
11	GND	Ground	C2	NC	
12	NC		C3	NC	
13	NC		C4	NC	
14	+5V	Power for monitor	C5	NC	
15	GND	Ground			

4.5 DVI Dual-Link Input

Location - JP38: 24+5P DVI-I Dual-Link



Pin assignment and definition:

Pin No.	Symbol	Description	Pin No.	Symbol	Description
1	Data 2-	Digital red- (link 1)	16	HPD	Hot plug detect

2	Data 2+	Digital red+ (link 1)	17	Data 0-	Digital blue- (link 1)
3	GND	Ground	18	Data 0+	Digital blue+ (link 1)
4	Data 4-	Digital green- (link 2)	19	GND	Ground
5	Data 4+	Digital green+ (link 2)	20	Data 5-	Digital green- (link 2)
6	DDC SCL	IIC serial clock	21	Data 5+	Digital green+ (link 2)
7	DDC SDA	IIC serial data	22	GND	Ground
8	NC		23	Clock+	Digital clock+ (link 1/2)
9	Data 1-	Digital green- (link 1)	24	Clock-	Digital clock- (link 1/2)
10	Data 1+	Digital green+ (link 1)	C1	NC	
11	GND	Ground	C2	NC	
12	Data 3-	Digital blue- (link 2)	C3	NC	
13	Data 3+	Digital blue+ (link 2)	C4	NC	
14	+5V	Power for monitor	C5	NC	
15	GND	Ground			

4.6 8-lanes V-by-One Interface Connector

Location - CNF1: 51P FPC connector pitch = 0.5mm(FI-RE51S-HF)

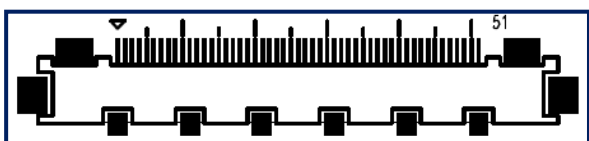

Pin assignment and definition:

Pin No.	Symbol	Description	Pin No.	Symbol	Description
1	GND	Ground	27	HTPDN	Hot plug detect
2	TX7P	Vx1 data lane7+	28	8b/10b	8-bit/10-bit select
3	TX7N	Vx1 data lane7-	29	NC	
4	GND	Ground	30	NC	
5	TX6P	Vx1 data lane6+	31	NC	
6	TX6N	Vx1 data lane6-	32	NC	
7	GND	Ground	33	SCL	IIC serial clock
8	TX5P	Vx1 data lane5+	34	SDA	IIC serial data
9	TX5N	Vx1 data lane5-	35	NC	
10	GND	Ground	36	NC	
11	TX4P	Vx1 data lane4+	37	NC	
12	TX4N	Vx1 data lane4-	38	GND	
13	GND	Ground	39	GND	
14	TX3P	Vx1 data lane3+	40	GND	

15	TX3N	Vx1 data lane3-	41	GND	Ground
16	GND	Ground	42	GND	Ground
17	TX2P	Vx1 data lane2+	43	NC	
18	TX2N	Vx1 data lane2-	44	PANEL_VCC	Panel power supply
19	GND	Ground	45	PANEL_VCC	Panel power supply
20	TX1P	Vx1 data lane1+	46	PANEL_VCC	Panel power supply
21	TX1N	Vx1 data lane1-	47	PANEL_VCC	Panel power supply
22	GND	Ground	48	PANEL_VCC	Panel power supply
23	TX0P	Vx1 data lane0+	49	PANEL_VCC	Panel power supply
24	TX0N	Vx1 data lane0-	50	PANEL_VCC	Panel power supply
25	GND	Ground	51	PANEL_VCC	Panel power supply
26	LOCKN	Lock detect			

4.7 8-lanes eDP(HBR) Interface Connector

Location - CNF2: 41P FPC connector pitch = 0.5mm(FI-RE41S-HF)



Pin assignment and definition:

Pin No.	Symbol	Description	Pin No.	Symbol	Description
1	PANEL_VCC	Panel power supply	22	TX5P	2 nd Lane1_P
2	PANEL_VCC	Panel power supply	23	TX5N	2 nd Lane1_N
3	PANEL_VCC	Panel power supply	24	GND	Ground
4	NC		25	TX4P	2 nd Lane0_P
5	GND	Ground	26	TX4N	2 nd Lane0_N
6	GND	Ground	27	VTX_HPD_1	1 st HPD
7	GND	Ground	28	AUX_CH_N_1	1 st AUX_CH_N
8	NC		29	AUX_CH_P_1	1 st AUX_CH_P
9	NC		30	GND	Ground
10	NC		31	TX3P	1 st Lane3_P
11	NC		32	TX3N	1 st Lane3_N
12	VTX_HDP_2	2 nd HPD	33	GND	Ground
13	AUX_CH_N_2	2 nd AUX_CH_N	34	TX2P	1 st Lane2_P
14	AUX_CH_P_2	2 nd AUX_CH_P	35	TX2N	1 st Lane2_N
15	GND	Ground	36	GND	Ground
16	TX7P	2 nd Lane3_P	37	TX1P	1 st Lane1_P

17	TX7N	2 nd Lane3_N	38	TX1N	1 st Lane1_N
18	GND	Ground	39	GND	Ground
19	TX6P	2 nd Lane2_P	40	TX0P	1 st Lane0_P
20	TX6N	2 nd Lane2_N	41	TX0N	1 st Lane0_N
21	GND	Ground			

4.8 4-lanes eDP(HBR2) Interface Connector

Location - CNF3: 30P FPC connector pitch = 0.5mm

Pin assignment and definition:

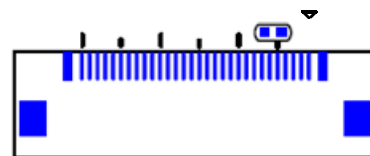

Pin No.	Symbol	Description	Pin No.	Symbol	Description
1	LCD_VCC	Panel power supply	16	Lane0_P	eDP Lane0+
2	LCD_VCC	Panel power supply	17	Lane0_N	eDP Lane0-
3	LCD_VCC	Panel power supply	18	GND	Ground
4	LCD_VCC	Panel power supply	19	Lane1_P	eDP Lane1+
5	LCD_VCC	Panel power supply	20	Lane1_N	eDP Lane1-
6	NC		21	GND	Ground
7	GND	Ground	22	Lane2_P	eDP Lane2+
8	NC		23	Lane2_N	eDP Lane2-
9	NC		24	GND	Ground
10	GND	Ground	25	Lane3_P	eDP Lane3+
11	HPD	Hot plug detect	26	Lane3_N	eDP Lane3-
12	GND	Ground	27	GND	Ground
13	AUX_CH_N	Auxiliary Channel-	28	GND	Ground
14	AUX_CH_P	Auxiliary Channel+	29	NC	
15	GND	Ground	30	GND	Ground

4.9 4-lanes eDP(HBR2) Interface Connector

Location - CNF4: 40P FPC connector pitch = 0.5mm

Pin assignment and definition:



Pin No.	Symbol	Description	Pin No.	Symbol	Description
1	NC		22	NC	
2	GND	Ground	23	GND	Ground
3	TX0N	Link lane0-	24	GND	Ground
4	TX0P	Link lane0+	25	GND	Ground
5	GND	Ground	26	GND	Ground

6	TX1N	Link lane1-	27	HPD	Hot plug detect
7	TX1P	Link lane1+	28	GND	Ground
8	GND	Ground	29	GND	Ground
9	TX2N	Link lane2-	30	GND	Ground
10	TX2P	Link lane2+	31	GND	Ground
11	GND	Ground	32	BL_ENA	Backlight on/off control
12	TX3N	Link lane3-	33	BL_DIM	PWM signal for dimming
13	TX3P	Link lane3+	34	NC	
14	GND	Ground	35	NC	
15	AUX_CH_P	Auxiliary Channel+	36	BL_PWR	Backlight power supply
16	AUX_CH_N	Auxiliary Channel-	37	BL_PWR	Backlight power supply
17	GND	Ground	38	BL_PWR	Backlight power supply
18	LCD_VCC	Panel power supply	39	BL_PWR	Backlight power supply
19	LCD_VCC	Panel power supply	40	NC	
20	LCD_VCC	Panel power supply			
21	LCD_VCC	Panel power supply			

4.10 8-port LVDS Interface Connector

Location - JN5: PH2.0 2x17P connector

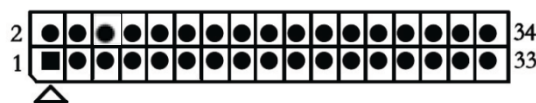

Pin assignment and definition:

Pin No.	Symbol	Description	Pin No.	Symbol	Description
1	VCC	Power supply for panel	18	TXA3+	LVDS A channel 3+
2	VCC	Power supply for panel	19	TXA4-	LVDS A channel 4-
3	VCC	Power supply for panel	20	TXA4+	LVDS A channel 4+
4	GND	Ground	21	TXB0-	LVDS B channel 0-
5	GND	Ground	22	TXB0+	LVDS B channel 0+
6	GND	Ground	23	TXB1-	LVDS B channel 1-
7	TXA0-	LVDS A channel 0-	24	TXB1+	LVDS B channel 1+
8	TXA0+	LVDS A channel 0+	25	TXB2-	LVDS B channel 2-
9	TXA1-	LVDS A channel 1-	26	TXB2+	LVDS B channel 2+
10	TXA1+	LVDS A channel 1+	27	GND	Ground
11	TXA2-	LVDS A channel 2-	28	GND	Ground
12	TXA2+	LVDS A channel 2+	29	TXBC-	LVDS B channel clock -
13	GND	Ground	30	TXBC+	LVDS B channel clock +
14	GND	Ground	31	TXB3-	LVDS B channel 3-
15	TXAC-	LVDS A channel clock -	32	TXB3+	LVDS B channel 3+

16	TXAC+	LVDS A channel clock +	33	TXB4-	LVDS B channel 4-
17	TXA3-	LVDS A channel 3-	34	TXB4+	LVDS B channel 4+

4.11 8-port LVDS Interface Connector

Location - JN7: PH2.0 2x17P connector

Pin assignment and definition:

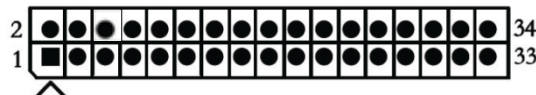

Pin No.	Symbol	Description	Pin No.	Symbol	Description
1	VCC	Power supply for panel	18	TXC3+	LVDS C channel 3+
2	VCC	Power supply for panel	19	TXC4-	LVDS C channel 4-
3	VCC	Power supply for panel	20	TXC4+	LVDS C channel 4+
4	GND	Ground	21	TXD0-	LVDS D channel 0-
5	GND	Ground	22	TXD0+	LVDS D channel 0+
6	GND	Ground	23	TXD1-	LVDS D channel 1-
7	TXC0-	LVDS C channel 0-	24	TXD1+	LVDS D channel 1+
8	TXC0+	LVDS C channel 0+	25	TXD2-	LVDS D channel 2-
9	TXC1-	LVDS C channel 1-	26	TXD2+	LVDS D channel 2+
10	TXC1+	LVDS C channel 1+	27	GND	Ground
11	TXC2-	LVDS C channel 2-	28	GND	Ground
12	TXC2+	LVDS C channel 2+	29	TXDC-	LVDS D channel clock -
13	GND	Ground	30	TXDC+	LVDS D channel clock +
14	GND	Ground	31	TXD3-	LVDS D channel 3-
15	TXCC-	LVDS C channel clock -	32	TXD3+	LVDS D channel 3+
16	TXCC+	LVDS C channel clock +	33	TXD4-	LVDS D channel 4-
17	TXC3-	LVDS C channel 3-	34	TXD4+	LVDS D channel 4+

4.12 8-port LVDS Interface Connector

Location - JN6: PH2.0 2x17P connector

Pin assignment and definition:

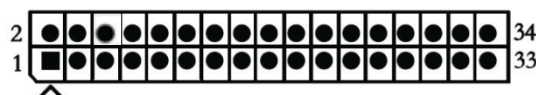

Pin No.	Symbol	Description	Pin No.	Symbol	Description
1	VCC	Power supply for panel	18	TXE3+	LVDS E channel 3+
2	VCC	Power supply for panel	19	TXE4-	LVDS E channel 4-
3	VCC	Power supply for panel	20	TXE4+	LVDS E channel 4+
4	GND	Ground	21	TXF0-	LVDS F channel 0-
5	GND	Ground	22	TXF0+	LVDS F channel 0+
6	GND	Ground	23	TXF1-	LVDS F channel 1-

7	TXE0-	LVDS E channel 0-	24	TXF1+	LVDS F channel 1+
8	TXE0+	LVDS E channel 0+	25	TXF2-	LVDS F channel 2-
9	TXE1-	LVDS E channel 1-	26	TXF2+	LVDS F channel 2+
10	TXE1+	LVDS E channel 1+	27	GND	Ground
11	TXE2-	LVDS E channel 2-	28	GND	Ground
12	TXE2+	LVDS E channel 2+	29	TXFC-	LVDS F channel clock -
13	GND	Ground	30	TXFC+	LVDS F channel clock +
14	GND	Ground	31	TXF3-	LVDS F channel 3-
15	TXEC-	LVDS E channel clock -	32	TXF3+	LVDS F channel 3+
16	TXEC+	LVDS E channel clock +	33	TXF4-	LVDS F channel 4-
17	TXE3-	LVDS E channel 3-	34	TXF4+	LVDS F channel 4+

4.13 8-port LVDS Interface Connector

Location - JN8: PH2.0 2x17P connector

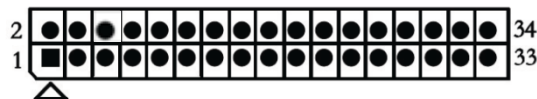

Pin assignment and definition:

Pin No.	Symbol	Description	Pin No.	Symbol	Description
1	VCC	Power supply for panel	18	TXG3+	LVDS G channel 3+
2	VCC	Power supply for panel	19	TXG4-	LVDS G channel 4-
3	VCC	Power supply for panel	20	TXG4+	LVDS G channel 4+
4	GND	Ground	21	TXH0-	LVDS H channel 0-
5	GND	Ground	22	TXH0+	LVDS H channel 0+
6	GND	Ground	23	TXH1-	LVDS H channel 1-
7	TXG0-	LVDS G channel 0-	24	TXH1+	LVDS H channel 1+
8	TXG0+	LVDS G channel 0+	25	TXH2-	LVDS H channel 2-
9	TXG1-	LVDS G channel 1-	26	TXH2+	LVDS H channel 2+
10	TXG1+	LVDS G channel 1+	27	GND	Ground
11	TXG2-	LVDS G channel 2-	28	GND	Ground
12	TXG2+	LVDS G channel 2+	29	TXHC-	LVDS H channel clock -
13	GND	Ground	30	TXHC+	LVDS H channel clock +
14	GND	Ground	31	TXH3-	LVDS H channel 3-
15	TXGC-	LVDS G channel clock -	32	TXH3+	LVDS H channel 3+
16	TXGC+	LVDS G channel clock +	33	TXH4-	LVDS H channel 4-
17	TXG3-	LVDS G channel 3-	34	TXH4+	LVDS H channel 4+

4.14 Power Input(External) Connector

Location - JP6: DC-005 2.5MM

4.15 Panel Touch Interface Connector

Location - CON1: 4P wafer pitch = 2.0mm

Pin assignment and definition:

Pin No.	Symbol	Description	Pin No.	Symbol	Description
1	USB_5V	USB 5V power	3	D+	USB data+
2	D-	USB data-	4	GND	Ground

4.16 Power Input(Internal) Connector

Location - CON2: 4P wafer pitch = 2.0mm

Pin assignment and definition:

Pin No.	Symbol	Description	Pin No.	Symbol	Description
1	GND	Ground	3	VIN	12V~24V DC input
2	GND	Ground	4	VIN	12V~24V DC input

4.17 UART Interface Connector

Location - CON3: 4P wafer pitch = 2.0mm

Pin assignment and definition:

Pin No.	Symbol	Description	Pin No.	Symbol	Description
1	GND	Ground	3	TX	UART-TX
2	RX	UART-RX	4	VCC	+3.3V output

4.18 Backlight Control Connector

Location - CON4: 6P wafer pitch = 2.0mm

Pin assignment and definition:

Pin No.	Symbol	Description	Parameter
1	BL-VCC	Power output for backlight	DC 12V/24V
2	BL-VCC	Power output for backlight	DC 12V/24V
3	BL_EN	Backlight on/off control	High: > 4V, Low: < 1V
4	BL_ADJ	PWM signal for dimming	DC 0~5V
5	GND	Ground	
6	GND	Ground	

4.19 GPIO Output Interface Connector

Location - CON7: 6P wafer pitch = 2.0mm

Pin assignment and definition:

Pin No.	Symbol	Description	Pin No.	Symbol	Description
1	GND	Ground	4	GPIO3	GPIO3 output
2	GPIO1	GPIO1 output	5	GPIO4	GPIO3 output
3	GPIO2	GPIO2 output	6	VCC	+3.3V output

4.20 PWM Output Interface Connector

Location - CON8: 6P wafer pitch = 2.0mm

Pin assignment and definition:

Pin No.	Symbol	Description	Pin No.	Symbol	Description
1	GND	Ground	4	PWM3	PWM3 output
2	PWM1	PWM1 output	5	VCC1	+3.3V output
3	PWM2	PWM2 output	6	VCC2	+5.0V output

4.21 USB Connector

Location - CON9: USB2.0 Type-B

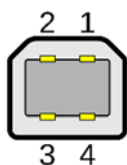

Type-B

Pin assignment and definition:

Pin No.	Symbol	Description	Pin No.	Symbol	Description
1	V _{BUS}	+5V	3	Data+	USB data+
2	Data-	USB data-	4	GND	Ground

4.22 ADC Input Interface Connector

Location - CON10: 4P wafer pitch = 2.0mm

Pin assignment and definition:

Pin No.	Symbol	Description	Pin No.	Symbol	Description
1	GND	Ground	3	ADC2	ADC2 Input
2	ADC1	ADC1 Input	4	VCC	+3.3V output

4.23 IIC Interface Connector

Location - CON11/CON13: 4P wafer pitch = 2.0mm

Pin assignment and definition:

Pin No.	Symbol	Description	Pin No.	Symbol	Description
1	GND	Ground	3	IIC_SDA	IIC serial data
2	IIC_SCL	IIC serial clock	4	VCC	+3.3V output

4.24 IR Receiver Interface Connector

Location - CON12: 3P wafer pitch = 2.0mm

Pin assignment and definition:

Pin No.	Symbol	Description	Pin No.	Symbol	Description
1	IR_IN	IR signal input	3	VCC	+5.0V output
2	GND	Ground			

4.25 Speaker Output Connector

Location - J2: 4P wafer pitch = 2.0mm

Pin assignment and definition:

Pin No.	Symbol	Description	Pin No.	Symbol	Description
1	L-OUT+	Speaker output left ch+	3	R-OUT-	Speaker output right ch-
2	L-OUT-	Speaker output left ch-	4	R-OUT+	Speaker output right ch+

4.26 Keypad Connector

Location - J6: 10P wafer pitch = 2.0mm

Pin assignment and definition:

Pin No.	Symbol	Description	Pin No.	Symbol	Description
1	K0	Key0 input	6	K2	Key2 input
2	R-LED	Red LED control	7	K3	Key3 input
3	G-LED	Green LED control	8	K4	Key4 input
4	GND	Ground	9	K5	Key5 input
5	K1	Key1 input	10	K6	Key6 input

4.27 RS-232 Interface Connector

Location - P1: DB-9

Pin assignment and definition:

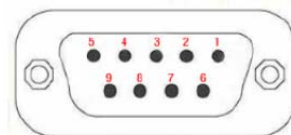

Pin No.	Symbol	Description	Pin No.	Symbol	Description
1	NC		6	NC	
2	232_TX	RS-232 TXD	7	NC	
3	232_RX	RS-232 RXD	8	NC	
4	NC		9	NC	
5	GND	Ground			

4.28 External Power Module Supply Input Interface

Location - J1: 13P wafer pitch = 2.54mm

Pin assignment and definition:

Pin No.	Symbol	Description	Pin No.	Symbol	Description
1	GND	Ground	8	+5V	+5V PWR Input
2	GND	Ground	9	GND	Ground
3	+5V	+5V PWR Input	10	GND	Ground
4	+5V	+5V PWR Input	11	GND	Ground
5	SW	Standby Control Output	12	+12V	+12V PWR Input
6	+5VON	+5V Input/Output	13	+12V	+12V PWR Input
7	+5V	+5V PWR Input			

5. Mechanical Dimension

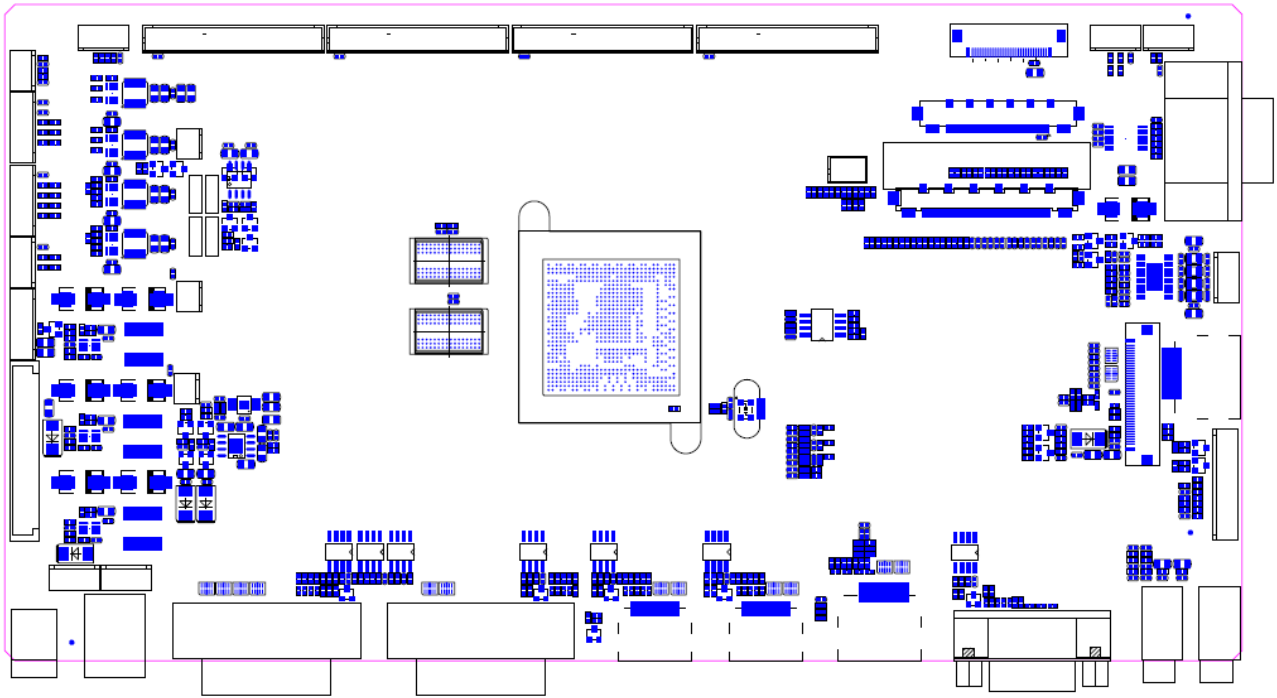

PCB Dimension

- PCB Length = 245.0mm
- PCB Width = 130.0mm
- PCB Thickness = 1.6mm
- PCBA(PCB + Component) Thickness \leq 16.0mm
- Screw Hole Diameter = 3.5mm

6. Configuration and Precautions

6.1 Temperature

✚ Storage: $-10^{\circ}\text{C}\sim+70^{\circ}\text{C}$

✚ Operation: $0^{\circ}\text{C}\sim+40^{\circ}\text{C}$

6.2 Humidity

✚ Storage: 5%~95%(non-condensing)

✚ Operation: 10%~90%(non-condensing)

6.3 Altitude

✚ Storage: 20000ft(Max.)

✚ Operation: 10000ft(Max.)

7. Key Materials List

No.	Part Number	Function Description	Vendor
1	RTD27xx	Scaler	Realtek
2	MP9943GQ-Z	DC-DC	MPS
3	MP2143DJ-LF-Z	DC-DC	MPS
4	W25Q16JVSSIQ	SPI flash	Winbond
5	CAT24C16WI-GT3	System EEPROM	ON
6	W631GG6KB-12	DDR3	Winbond
6	7U14318E20UCG	SMD Crystal	SJK
7	AD52068	Class-D AMP 2x10W	ESMT
8	PCB	1.6mm FR-4 E=4.2 ±10% 4-Layers 1.0oz 245.0x130.0mm	BYF